

# Nursery & Horticultural Equipment



ABN 75 002 149 804  
72-74 Mandon Rd, GIRRAWEE NSW 2145 Australia

**Phone: 02 9631 6000**

Fax: 02 9688 4679

Web Site: [www.cmac.com.au](http://www.cmac.com.au)

Email: [sales@cmac.com.au](mailto:sales@cmac.com.au)

## “Spring” Nursery Benches



- Supplied in kit form to minimise the transport costs.
- Made from heavy duty galvanised (internal & external) steel tube 25.4mm OD x 1.6mm thick.
- Special sized 75mm x 25mm x 4mm diameter galvanised mesh used on all benches.
  - Allows pots to sit on mesh right up to the edges of the bench, without falling over.
  - Mesh snaps easily over steel tubing, holding it tight (no fasteners).
- Available in lengths of 2350mm, 1750mm and 1180mm.
- Heights:
  - 750mm – single layer benches
  - 150mm and 750mm – double layer benches
  - 150mm, 750mm and 1350mm – triple layer benches
- Standard widths are: 300mm, 525mm, 775mm, 1150mm and 1225mm.
- Continuous length and special bench kits made to order.
- 2 Tier, 3 Tier and shade covered 3 Tier benches are also available as standard.

- Single layer and Double layer benches can also be supplied with a 10° sloping top shelf.

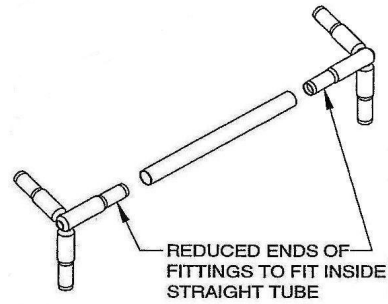

“Spring Benches” can be assembled in a few minutes without the need for any bolts, screws or other fasteners. The various tubes simply slide into the appropriate sockets to create a strong assembly. Even after twenty years the benches can be disassembled simply by pulling them apart, providing a smear of petroleum jelly has been applied inside the fittings before assembly.



Many specials have been designed and manufactured over the years.

With our diverse design and large, well-equipped manufacturing facility we can provide benching and material handling equipment to suit any of your special needs.

**Phone: 02 9631 6000**



Other Divisions:

C-Mac Engineering & Gearcutting

C-Mac Sheetmetal

